

AFRICAN PREMIUM EQUIPMENT

PALFINGER

LIFETIME EXCELLENCE

THE PALFINGER CRANE AS A MULTIFUNCTIONAL MACHINE. COMBINED WITH EQUIPMENT, THE CRANE BECOMES A CHAMPION OF VERSATILITY.



LIFETIME EXCELLENCE

THE PALFINGER EQUIPMENT CENTER OFFERS AN EXTENSIVE RANGE OF ATTACHMENTS – EQUIPPED WITH THE APPROPRIATE ATTACHMENT, THE CRANE BECOMES A **MULTI-FUNCTIONAL MACHINE** AND WORKS **COST-EFFECTIVELY**

BETTER SOLUTIONS

BETTER EFFICIENCY

BETTER ERGONOMICS

HIGHER VALUE RETENTION



HIGHER AVAILABILITY

HIGHER SERVICEABILITY

BETTER ECOLOGY

MORE RELIABILITY



EFFICIENCY AND MAXIMUM QUALITY FOR CUSTOMER SUCCESS





- Wide range of products for any application
- One stop – a single contact for both the crane and the equipment
- PALFINGER warranty & service
- Highest product quality thanks to the cooperation with well-established suppliers



ROTATOR PACKAGES



- Complete package including the link, hoses and hook for easy mounting
- Including pressure relief valve for safe operation
- Stops accurately even at maximum load

TECHNICAL SPECIFICATIONS

Type	Load capacity (kg)	Torque (Nm)	Deflection moment max (Nm)	Self weight (kg)
PZR300GPK	3000	450	1750	39
PZR450GPK	4500	850	3000	45
PZR601GPK	6000	1000	4500	63

* Other types of rotators on request

TRUCK CRANE REQUIREMENTS

Operating pressure 320 bar
 Pump capacity 25 – 60 l/min
 One hydraulic function on the crane



PREMIUM BRICK STACK GRAPPLE



- Complete package including the link, rotator, compression rails and hoses
- Versatile tool for handling bricks and blocks
- Adjustable plunge depth for loading pallets with different heights
- Safe clamping thanks to pressure relief and non return valve

TECHNICAL SPECIFICATIONS

Type	Load capacity* (kg)	Plunge depth A (mm)	Gripping (mm)	Self weight (kg)
PZS321-PK	2000	790	780 – 1400	401
	1500	1310		

* at max/min plunge depth

TRUCK CRANE REQUIREMENTS

Operating pressure 200 – 260 bar
 Pump capacity 25 – 75 l/min
 Two hydraulic functions on the crane

PLEASE NOTE

The listed load capacity depends on the surface conditions and the size and type of banding. The load capacity does not apply to loose/unbanded concrete or paving stones.

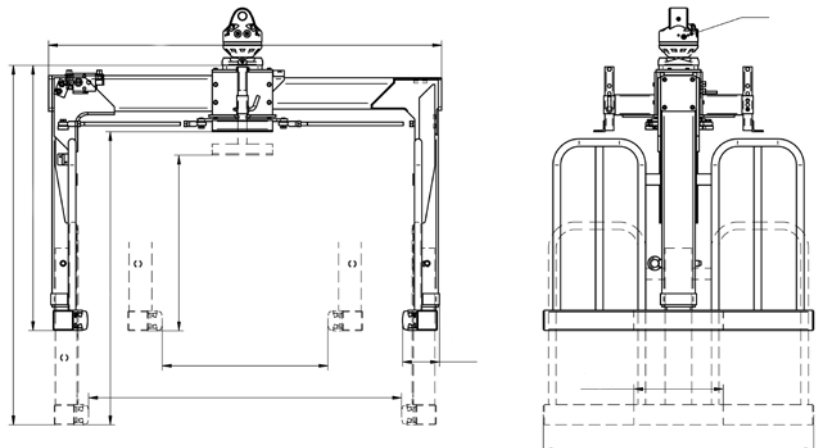

BRICK STACK GRAPPLE - SCISSORS



- Complete package including the link, rotator, compression rails and hoses
- Easy handling thanks to the synchronised function of the clamping arms
- Parts with small dimensions can be picked up thanks to scissors technology

TECHNICAL SPECIFICATIONS

Type	Load capacity (kg)	Plunge depth A (mm)	Gripping G (mm)	Self weight (kg)
PZS100SP	2000	1000	200 – 1420	315
PZS120SP	1800	1200	98 – 1475	325

* Other types of brick stack grapples on request

TRUCK CRANE REQUIREMENTS

Operating pressure 200 – 320 bar
 Pump capacity 25 – 75 l/min
 Two hydraulic functions on the crane

PLEASE NOTE

The listed load capacity depends on the surface conditions and the size and type of banding. The load capacity does not apply to loose/unbanded concrete or paving stones.

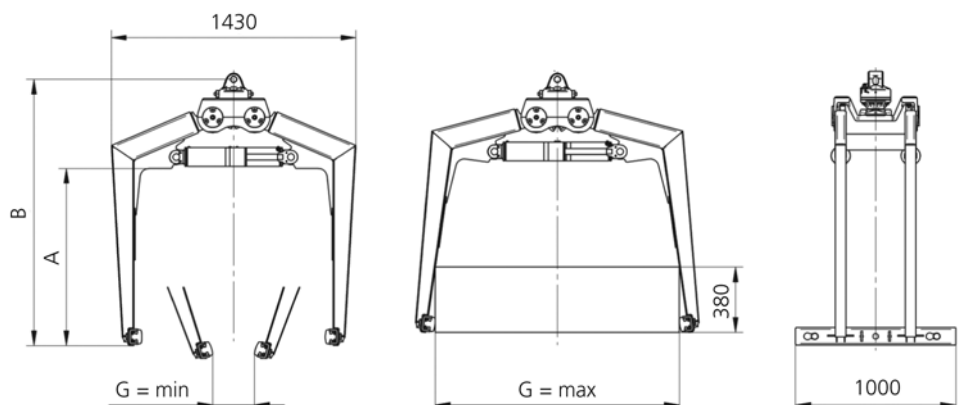

CLAMSHELL BUCKET



- Complete package including clamshell bucket with bolt-on teeth, rotator, link and hoses
- Long life thanks to the high quality steel (500 HB) and a generously dimensioned bearing system
- Excellent digging characteristics thanks to the high closing force of 20 kN at 260 bar operating pressure

TECHNICAL SPECIFICATIONS

Type	Volume (litre)	Width B (mm)	Number of teeth	Load capacity (kg)	Total weight (kg)
PZG150GPK	150	325	3	3000	210
PZG250GPK	250	500	5	3000	255
PZG350GPK	350	650	5	3000	275
PZG450GPK	450	800	9	3000	310
PZG550GPK	550	1000	9	3000	345

TRUCK CRANE REQUIREMENTS

Operating pressure 260 – 320 bar
 Pump capacity 25 – 75 l/min
 Two hydraulic functions on the crane

ACCESSORIES ON REQUEST

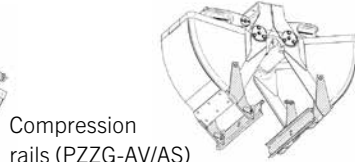
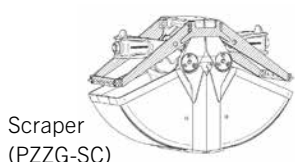

You can get detailed information on the diverse types from your local PALFINGER dealer.

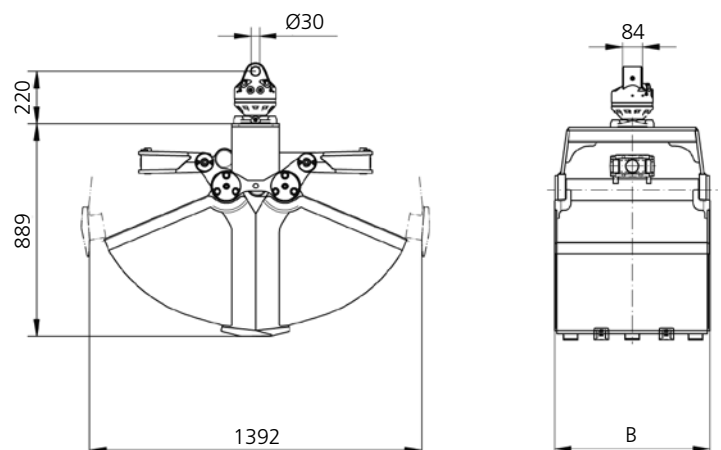

HIGH VOLUME CLAMSHELL BUCKET



- Complete package including the link, rotator, hoses and welded hooks
- Ideal for handling bulk materials and for light digging operation
- High stability and torsion-free frame, thanks to reinforced buckets, generously dimensioned bearing system

TECHNICAL SPECIFICATIONS

Type	Volume (l)	Width B (mm)	Load capacity (kg)	Self weight (kg)
PZG300S-1P	300	640	3000	352
PZG400S-1P	400	800	3000	382
PZG500S-1P	500	1000	3000	407

* Other types of clamshell buckets on request

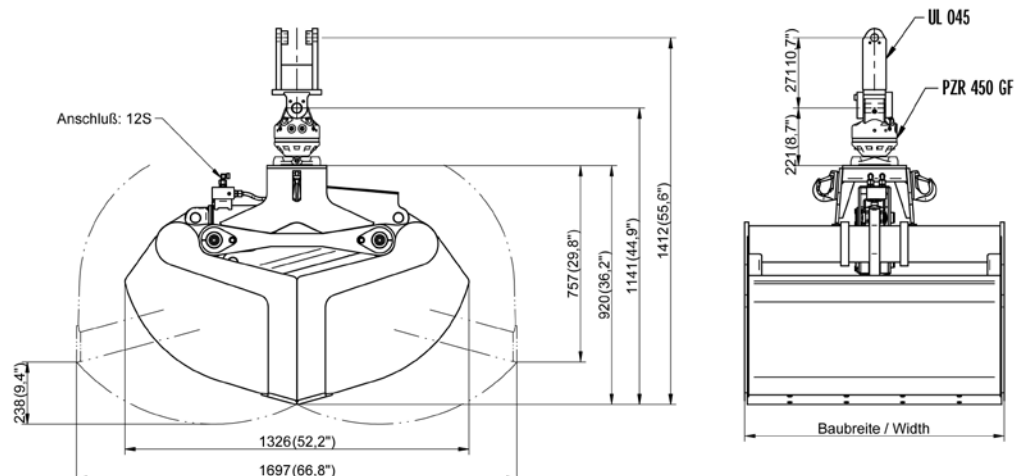

TRUCK CRANE REQUIREMENTS

Operating pressure 200 – 320 bar
 Closing force 20 (kN) at 260 bar
 Pump capacity 35 – 75 l/min
 Two hydraulic functions on the crane

PALLET FORK



- Easy shifting of the collar, enables handling of different loads
- Easy adjustable throat height and tine spread
- Robust and economic product to handle pallets

TECHNICAL SPECIFICATIONS

Type	Load capacity (kg)	Throat height A (mm)	Tine spread Z (mm)	Self weight (kg)
PZP150	1500	1000 – 1600	325 – 920	120
PZP200	2000	1000 – 1600	345 – 940	130

* Other types of pallet forks on request

TRUCK CRANE REQUIREMENTS

For hook operation

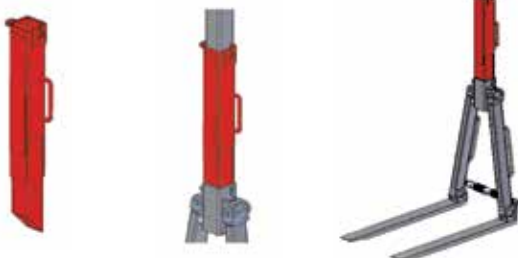

Including a protection chain. An optional extension is available separately for throat heights from 1750 to 2350 (PZPEX750).

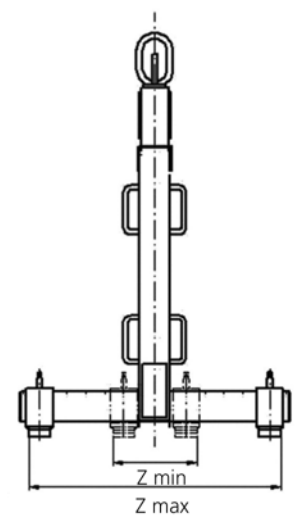
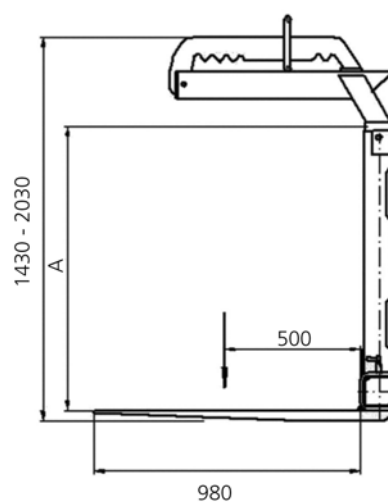

BARRIER LIFTER



- Fast and convenient handling of concrete barriers and blocks
- Maximum safety thanks to carbide gripping pads
- Easy handling thanks to mechanical “latch & release” system
- The pin position can be easily changed for different gripping ranges

TECHNICAL SPECIFICATIONS

Type	Opening range (mm)	Self weight (kg)	Load capacity max. (kg)
PZB932-6/10	100 – 310	150	6580
PZB332-12/14	285 – 400	115	6580

* For hook operation

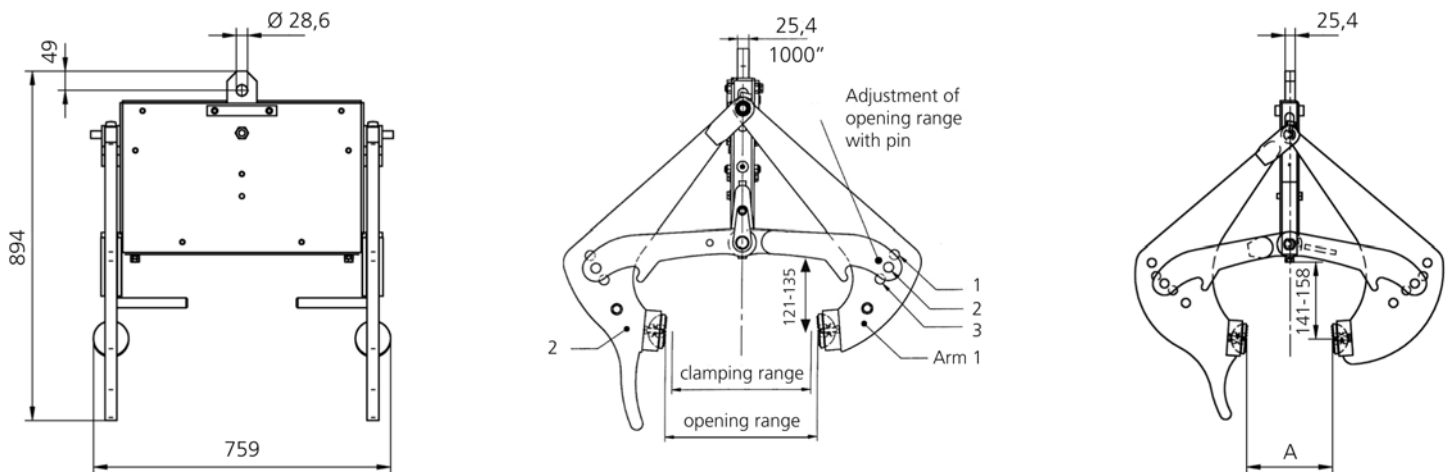

WORKMAN BASKET



- Safe basket operation thanks to levelling system and disc brake
- Optimised equipment for loader cranes
- Includes integrated tool box
- Easy and quick mounting on the crane

TECHNICAL SPECIFICATIONS

Type	Load capacity (kg)	Self weight (mm)	Entry width (mm)
BB004	280 kg (2 persons and tools)	188	520

Basket operation requires crane with Radio Remote Control.

Equipment such as safety harnesses (PZBB01 /PZBB02) and different pull-in parts are also available from PALFINGER.

TRUCK CRANE REQUIREMENTS

Pull-in Part

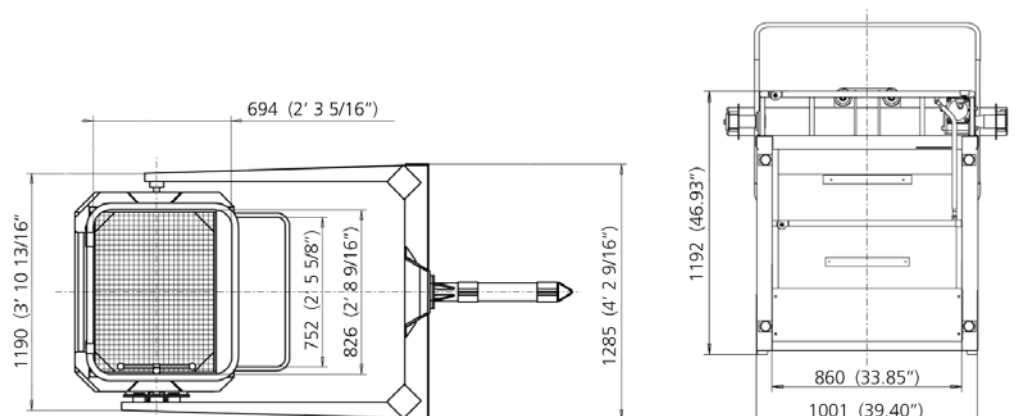

EARTH AUGER



- Highest drilling performance in earth, gravel layers or soft rock
- Augers with diameters from 150 mm to 900 mm available
- The correct auger for any condition (earth, gravel layers, soft rock)
- No extra overflow oil line necessary (leak oil)

TECHNICAL SPECIFICATIONS

Diameter*	150	200	225	250	300	350	400	500	600	800
Needed auger drive	BEG30	BEG30	BEG30	BEG50	BEG50	BEG50	BEG50	BEG50	BEG80	BEG80
Max. depth (mm)	2000	2000	2000	4500	4500	4500	4500	4000	6000	3000
Recommended crane	>9 mt	>9 mt	>9 mt	>12mt	>12mt	>12mt	>12mt	>12mt	>15mt	>15 mt

* For drilling in earth, soft rock and gravel layers available

TRUCK CRANE REQUIREMENTS

Operating pressure 260 bar
 Pump capacity 20 – 50 l/min
 One hydraulic function on the crane

ACCESSORIES ON REQUEST

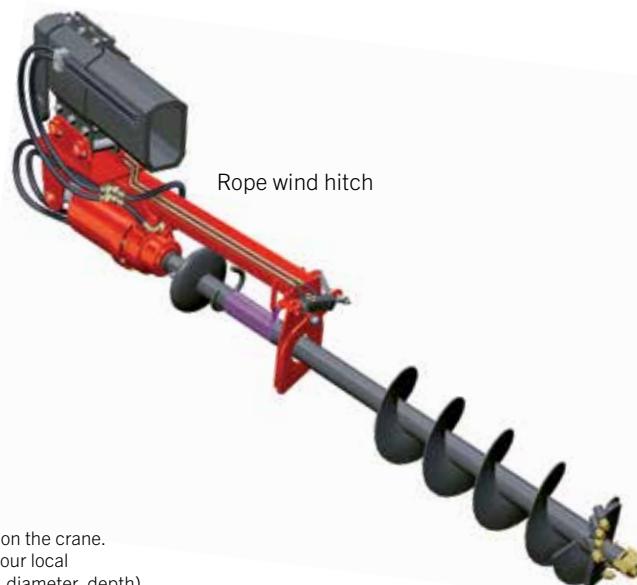

PLEASE NOTE:
 Drilling is only allowed with a maximum of two extended booms on the crane.
 For optimised configuration of the earth auger, please contact your local
 PALFINGER dealer who will specify the drilling details (material, diameter, depth).

CAR LIFTING DEVICE



- Easy and quick loading and unloading procedure thanks to the most advanced technical features such as the mushroom lock system
- Easy adjustment for any vehicle
- Two different systems available
- Safe handling of all vehicles thanks to the hydraulic levelling in the PZLG35PK

TECHNICAL SPECIFICATIONS

PZLG35PK

3500 KG CAR-LIFTING DEVICE FOR DAILY USE

Complete set including:

- Car-lifting device with hydraulic adjustment of the centre of gravity
- Rotator, link and hoses
- Wheel clamp straps with adjustable length (1.3/1.5/1.7 m)
- 4 wheel clamps for wheel sizes between 12" and 19" and a width of 355 mm
- Bracket for easy storage on the vehicle



PZLG20HPK

2000 KG MECHANICAL CAR-LIFTING DEVICE FOR NON FREQUENT- USE

Complete set including:

- Car-lifting device for hook operation
- Wheel clamp straps with adjustable length (1.3/1.5/1.7 m)
- 4 wheel clamps for wheel sizes between 12" and 19" and a width of 355 mm
- Bracket for easy storage on the vehicle

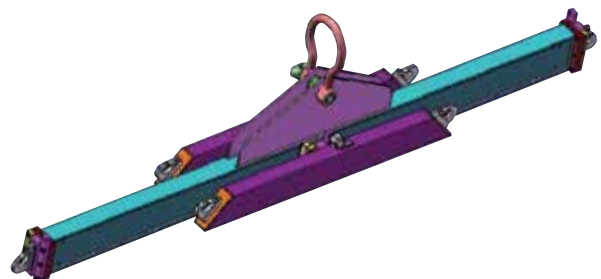

VACUUM LIFTING DEVICE



- Complete set for hook operation for lifting glass and metal sheets
- Two vacuum circuits for the highest level of safety
- Manual suction frame can be turned to any angle
- No extra hydraulic or electrical connection needed

TECHNICAL SPECIFICATIONS

Type	Number of suction pads	Suction dimension (mm)	Load capacity (kg)	Self weight (kg)
PZA500	8	1390 x 950	500	82
PZA700	10	1390 x 950	700	100

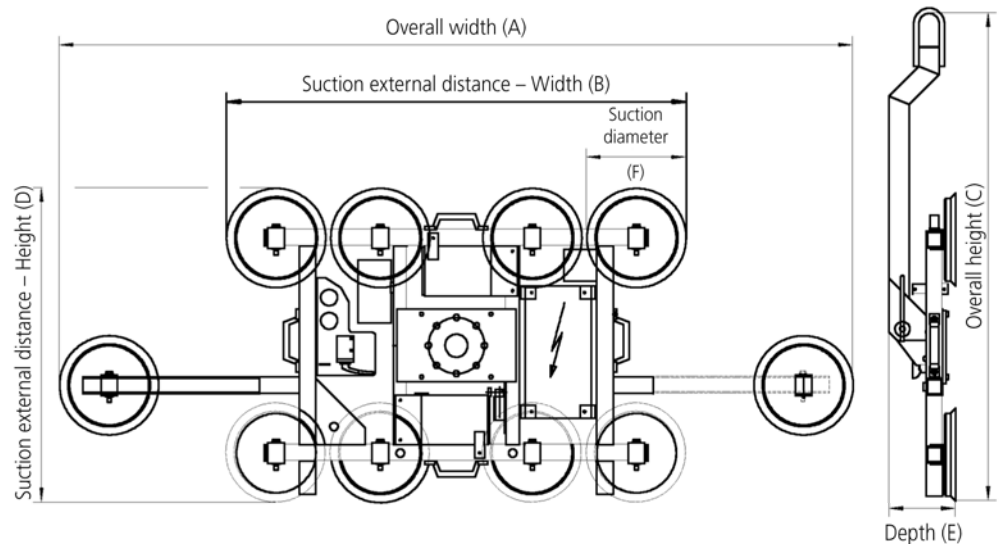

TRUCK CRANE REQUIREMENTS

Charging voltage	220 V
Voltage vacuum pump	12 V
Suction diameter	290 mm

Transport cart PZATW available.

ACCESSORIES FOR STABILISERS



- Suitable for all stabilisers
- Easy and fast handling thanks to the carrying straps
- Transport boxes suitable for all dimensions
- Highest possible supporting force tested by PALFINGER

TECHNICAL SPECIFICATIONS

Type	Description	Dimensions (mm)	Supporting force max. (t)	Weight (kg)
EZ2261-400	Round stabiliser pad	Ø 400 / 80	12	5
EZ2261-500	Round stabiliser pad	Ø 500 / 80	16	7
EZ2263-400	Box for 1 x EZ2261-400			2.6
EZ2263-500	Box for 1 x EZ2261-500			3.2
EZ2189-300	Square stabiliser pad	300 x 300 x 40	9	3.5
EZ2189-400	Square stabiliser pad	400 x 400 x 50	16	8
EZ2189-500	Square stabiliser pad	500 x 500 x 60	26	15
EZ2189-600	Square stabiliser pad	600 x 600 x 60	36	21
EZ2189-800	Square stabiliser pad	800 x 800 x 60	35	35
EZ2190-300	Box for 2 x EZ2189-300			4.3
EZ2190-400	Box for 2 x EZ2189-400			6.3
EZ2190-500	Box for 2 x EZ2189-500			8.4
EZ2190-600	Box for 2 x EZ2189-600			10.4
EZ2190-800	Box for 1 x EZ2189-800			13

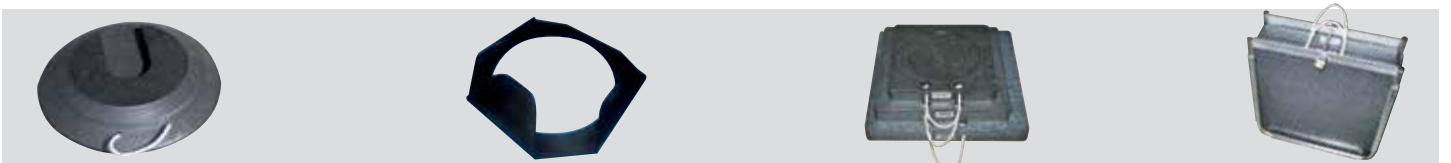

PERFECT TOOL FOR EACH DEMAND HIGHLIGHTS & FURTHER PRODUCTS

06

HIGHLIGHTS



DEVELOPMENT
RELIABLE AND SUCCESSFUL

Interest is focused on topics like ergonomics, functionality, weight and material optimisation.



SALES AND PROJECT ENGINEERING
COMPETENCE

Experienced sales experts advise and support you when selecting a product and the configuration so that the loading solution matches your application conditions exactly.

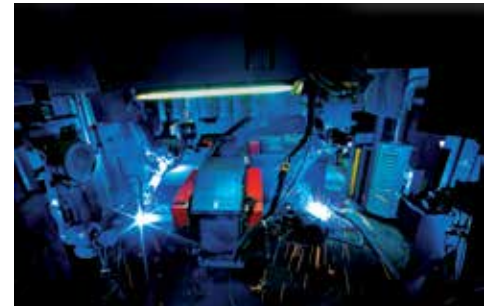

PRODUCTION TECHNOLOGY
LATEST TECHNOLOGIES

The cornerstone for quality is laid in production. In the field of steel processing and machining, PALFINGER has the latest cutting, edging and welding technologies at its production sites.



QUALITY MANAGEMENT
INTERNAL AND EXTERNAL AUDIT

Our certified quality management system is compliant with ISO 9001 and ensures process-reliable production and the high quality of our products.



SERVICE AND TECHNICAL SUPPORT
MORE EFFICIENCY IN USE

PALFINGER provides an extensive service network. The highly trained personnel of our service partners and licensed workshops provide help quickly.



SPARE PARTS SUPPLY
HIGHEST AVAILABILITY

Several spare parts centres worldwide guarantee a seamless supply of spare parts. All original spare parts are tested and comply with the PALFINGER quality standard.



ORANGE PEEL GRAPPLES
MULTIPURPOSE

PALFINGER offers a wide range of orange peel grapples for waste and scrap handling. Available with 4 and 5 tines and with half or fully closed tines.



UNIVERSAL BUCKETS
TWO IN ONE

A robust clamshell bucket and versatile tool for handling refuse material. The open side of the grapple enables the handling of bulk material.



MANIPULATORS
PRECISE POSITIONING

A hydraulically operated attachment used for positioning tubes or poles. For loads from 500 kg to 3000 kg.



UNIVERSAL FORKS
SAFE POSITIONING

The universal fork for loader cranes handles wallboards and other flat building materials that have been delivered up to a size of 1250 mm height and 460 mm depth.



CUSTOMISED PRODUCTS
FOR EACH REQUEST

On request, PALFINGER is able to offer customised products for special applications. Please contact your sales representative for further information.



ADDITIONAL STABILISERS
IMPROVED SUPPORT

The new additional stabilizers are adapted optimally to the demands of the PALFINGER crane. A variety of improvements make the stabilisers to an ideal accessory.



PUMPS
FOR EACH CRANE

PALFINGER offers a big variety of constant and load-sensing pumps for any requirement.



OIL COOLERS
FOR EACH CRANE

PALFINGER oil coolers are offered from 8.5 kW to 20.0 kW depending on the crane size. The crane can be operated in a very hot climate and with high load cycles.



OIL TANKS
HIGH VOLUME AND QUALITY

Depending on the requirement, PALFINGER offers additional oil tanks from 75 l to 425 l made of steel or aluminium.

